

Part number

CHPT 16.5



Brief description:

surface mounting housings with 2 levers, size "77.27", 3/4" NPT, metal version, IP66

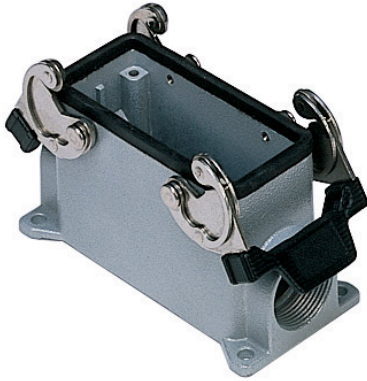

Product description

Version	metal version
Series	surface mounting housings with 2 levers
Product type	with 2 levers
Family	CLASS enclosures
Size	size "77.27"

Technical data

Material	metal
IP degree of protection	IP66 (and IP69K DIN 40050 - 9)
Cable entry	3/4" NPT

Further technical details

Weight	355,00 g
--------	----------

Approvals / Standards

Quality mark	 (type:4/4X/12),  , EAC
Conformity	CQC, CE

General ordering information

EAN13 code	8015747023603
Tariff number	85369095

Packaging Information

Packaging length	475,00 mm
Packaging height	180,00 mm
Packaging width	175,00 mm
Packaging weight	7,10 kg
Packaging volume	14,96 dm ³
Packaging description	Carton box
Packaging quantity	10 Pcs
Packaging EAN code	8015747250962
Sub-packaging weight	3,55 kg
Sub-packaging description	Carton Box
Sub-packaging quantity	5 Pcs
Sub-packaging EAN barcode	8015747023627

Part number

CHPT 16.5



Catalogue drawings

CHP CAP - MHP MAP

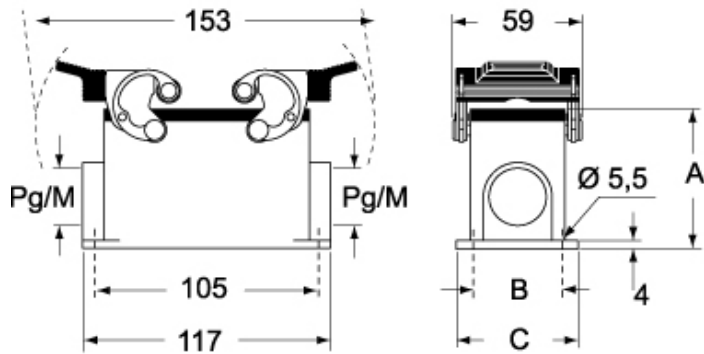

CHP CS/CP CAP CS/CP - MHP CS/CP MAP CS/CP

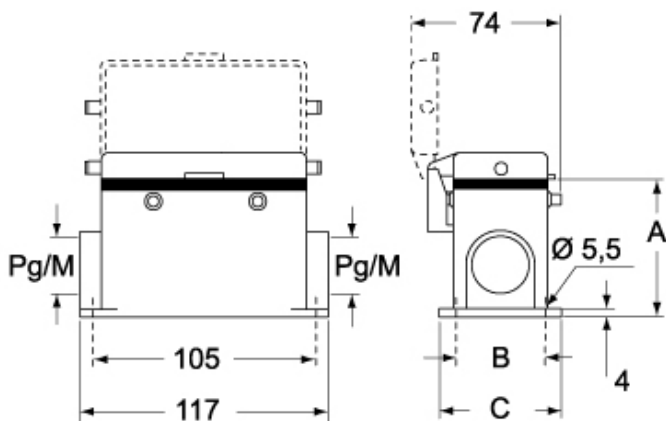

	A
CHP / MHP	63
CAP / MAP	77
CHP CS / MHP CS	63
CAP CS / MAP CS	77
CHP CP / MHP CP	63
CAP CP / MAP CP	77